

<b>MODEL</b>	<b>NRR EV</b>
<b>GVWR / GCWR</b>	19,500 lbs. / 19,500 lbs.
<b>WB</b>	132.5 in., 150 in., 176 in.
<b>CA</b>	110 in., 127.5 in., 153.5 in.
<b>ELECTRIC MOTOR</b>	ZF CeTrax Lite 3-phase AC motor
<b>OPERATING VOLTAGE</b>	350 Volts
<b>MAX POWER OUTPUT</b>	150 kW
<b>MAX TORQUE OUTPUT</b>	280 lb-ft
<b>EQUIPMENT</b>	Motor sub-assembly includes an integrated DC-AC Inverter, single speed reduction gear, and motor control unit.
<b>HIGH VOLTAGE BATTERY PACKS</b>	Liquid cooled lithium ion high-voltage battery packs. Each pack features 20 kWh of battery capacity. Chassis are available in 3, 5, 7, or 9 battery pack configurations depending on wheelbase.
<b>AC STANDARD CHARGING</b> SAE J1772 Connector	7.2 kW on 60 kWh chassis 19.2 kW on 100/140/180 kWh chassis
<b>DC FAST CHARGING</b> CCS1 Connector	42 kW on 60 kWh chassis 70 kW on 100 kWh chassis 80 kW on 140/180 kWh chassis
<b>STEERING</b>	Integral power steering 18.8-20.9:1 ratio. Tilt and telescoping steering column.
<b>FRONT AXLE</b>	Reverse Elliot "I" -beam rated at 7,275 lbs.
<b>FRONT SUSPENSION</b>	Semi-elliptical steel alloy tapered leaf springs with stabilizer bar and shock absorbers.
<b>FRONT GAWR</b>	7,275 lbs.
<b>REAR AXLE</b>	Full floating single speed with hypoid gearing rated at 14,550 lbs.
<b>REAR SUSPENSION</b>	Semi-elliptical steel alloy multi-leaf springs and shock absorbers.
<b>REAR GAWR</b>	14,460 lbs.
<b>WHEELS</b>	19.5 X 6.0-K 6 hole disc wheels, painted white
<b>TIRES</b>	225/70R-19.5 LRR (Low Rolling Resistance) tubeless steel belted radials, all season, front and rear.
<b>TIRE PRESSURE MONITORING SYSTEM (TPMS)</b>	Tire pressure sensors are installed onto each wheel to detect changes in tire pressure and tire temperature. TPMS status will be displayed within the instrument panel.
<b>BRAKES</b>	Dual circuit power assisted hydraulic 4-channel anti-lock service brake system with EBD (Electronic Brake Distribution) for load proportioning of the front and rear disc brakes. The parking brake is a mechanical, electronically actuated, internal expanding drum type, driveshaft mounted.
<b>REGENATIVE BRAKING</b>	Adjustable regenerative braking with multiple strength levels. Braking strength can be quickly adjusted between High, Low and OFF using the steering wheel stalk switch.
<b>FRAME</b>	Ladder type channel section straight frame rail 33.5 in wide through the total length of the frame. Yield strength 54,800 psi section modulus 6.65 cubic in, RBM 364,420 lb-in
<b>CAB</b>	All steel, low cab forward, BBC 65.9 in, 45° mechanical tilt with torsion assist.
<b>CAB EQUIPMENT</b>	Gray breathable cloth covered high back driver's seat equipped with an armrest along with two occupant passenger seat. Dual cab mounted exterior mirrors with integral convex mirror, power windows and door locks, floor mats, tinted glass and air conditioning. AM/FM radio with auxiliary input, USB port and Bluetooth. Rear body dome lamp switch and cab latch switch with indicator and buzzer. Interior and exterior lights are all LED (excluding the rear taillight assembly). Driver and outboard passenger front supplemental restraint system air bags.
<b>ADAS</b>	Advanced driver assistance systems including: Automatic emergency braking, following distance warning, forward vehicle start notification, mis-acceleration mitigation system, full-range adaptive cruise control, lane departure warning, and driver attention assist.
<b>ELECTRICAL</b>	Two 12-volt group 34, negative ground, maintenance free batteries located on frame, 700 CCA, supplied by DC-DC converter
<b>OPTIONS</b>	See last page for options.

**Note:** These selected specifications are subject to change without notice.

VEHICLE WEIGHTS, DIMENSIONS AND RATINGS

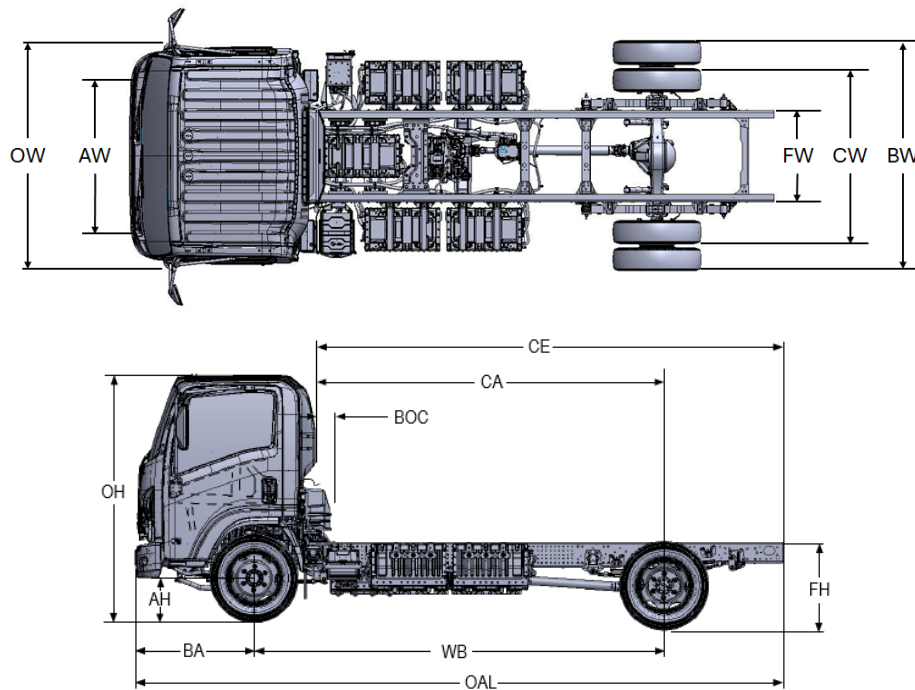

Figure 1: NRR EV Cab Chassis Dimensions

CHASSIS DIMENSIONS (in.)				
WB	CA[1]	CE[2]	AF	OAL
132.5	110.0	153.1	43.1	224.0
150	127.5	170.6	43.1	241.5
176	153.5	196.6	43.1	267.5
DIMENSION CONSTANTS (in.)				
AW = Front axle track				65.6
BA = Front bumper to centerline of axle				48.3
BBC = Bumper to back of cab				70.9
BOC = Back of cab clearance				7.7
BW = Overall width across rear axle				83.3
CW = Rear axle track				65
FW = Frame width				33.5
OW = Overall width across cab (without mirrors)				81.3
VARIABLE DIMENSIONS BY GVWR (in.)			17,950 lb.	19,500 lb.
AH = Ground to bottom of axle			7.5	7.5
FH = Frame height (unladen) at E.O.F.[3]			33	33
OH = Overall height (without clearance lights)			92.4	92.4

CHASSIS CURB WEIGHTS AND PAYLOADS						GVWR	
N-SERIES EV STANDARD CAB						17,950 lbs.	19,500 lbs.
MODEL	WB (in)	Battery Capacity (kWh)	Front (lbs)	Rear (lbs)	Total (lbs)	Payload (lbs)	Payload (lbs)
6U2-03	132	60	4139	2410	6549	11401	12951
6U2-05	132	100	4547	3016	7563	10387	11937
6U3-03	150	60	4256	2346	6602	11348	12898
6U3-05	150	100	4734	2882	7616	10334	11884
6U4-03	176	60	4452	2247	6699	11251	12801
6U4-05	176	100	5010	2706	7716	10234	11784
6U4-07	176	140	5268	3416	8684	9266	10816
6U4-09	176	180	5548	4070	9618	8332	9882

- Notes:
- [1] Effective CA is CA less BOC.
  - [2] Effective CE is CE less BOC.
  - [3] Measured at the end of the frame from the top of the frame to the ground at curb
  - [4] Chassis curb weight reflects standard equipment and fuel, but no driver or payload.
  - [5] Maximum Payload Weight is the allowed maximum for equipment, body, payload and driver and is calculated by subtracting chassis curb weight from the GVWR.

Vehicle Weight Limits	NRR Derate EV	NRR EV
GVWR Designed Maximum (lbs.)	17,950	19,500
GCWR Combined Maximum (lbs.)	19,500	19,500
GAWR - Front (lbs.)	6,830	7,275
GAWR - Rear (lbs.)	13,660	14,460

Note: NRR Derate EV is applicable to NRR chassis with PIO IZ5

**ModelDescription**

The N-Series features a low cab forward design that is ideally suited for inter-city type applications. The low cab forward design minimizes overall length for a given body length and in conjunction with the set back front axle positioning provides excellent weight distribution. The 46.5° inside wheel cut angle coupled with integral power steering make it an extremely maneuverable truck.

**Motor**

The NRR-EV is powered by the ZF CeTrax Lite 3-Phase AC Motor. This motor is designed for a zero emissions solution with enhanced durability and reliability. The motor sub-assembly includes an integrated DC-AC inverter, single speed reduction gear, and MCU (Motor Control Unit). The driving motor rotates according to the AC voltage and frequency supplied from the inverter and has a maximum output of 150 kW. The inverter takes direct current (DC) supplied from the high voltage batteries and converts it to a 3-phase alternating current (AC). According to the requests from the VCU, the AC voltage and frequency are changed to control the motor output. The motor assembly also has a built-in parking pawl mechanism.

**VehicleAssistFeatures**

NRR EV chassis are factory equipped with Electronic Stability Control (ESC), which includes Anti-Slip Regulation (ASR). ESC improves safety by enhancing the vehicle’s ability to maintain stability by electronically controlling engine power and applying braking as needed to help the driver stay on their intended course. ASR or Traction Control helps suppress wheel spin and can assist with launch performance on certain low traction surfaces. While driving, ASR works with ESC to help prevent skidding during turns and improve overall vehicle stability. In addition, Advanced Driver Assistance System (ADAS) is standard on all NRR-EV chassis. ADAS features the following systems: Automatic Emergency Braking, Following Distance Warning, Mis-Acceleration Mitigation, Full-Range Adaptive Cruise Control, Lane Departure Warning, and Attention Assist. Please reference the vehicle’s Owner’s Manual for additional information.

**Electric Motor Data: ZF CeTrax Lite 3-Phase AC Motor**

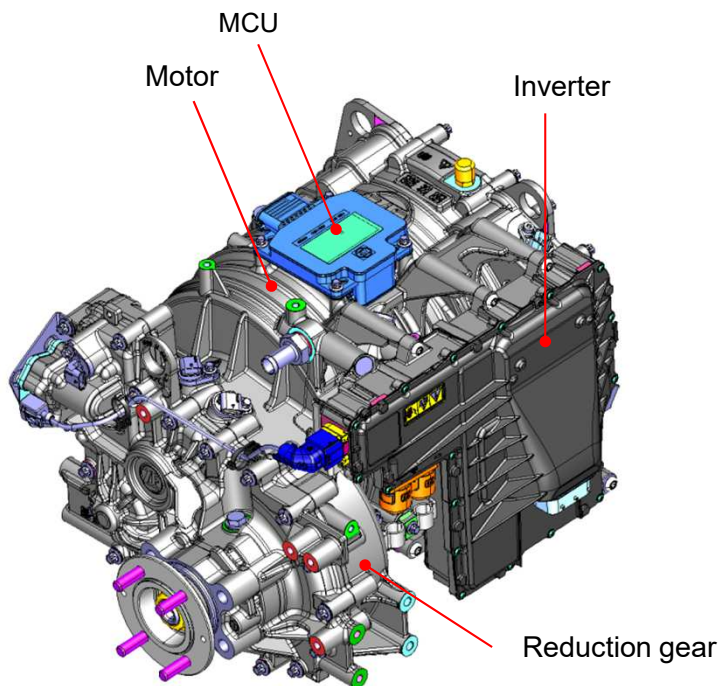

Operating Volage	350 Volts
Max Power Output	150 kW
Max Torque Output	280 lb-ft
Max Rev.	13,000 rpm
Max Speed	65 mph

Figure 2: NRR EV Motor

**Front Axle**

The NRR EV front axle is a drop forged steel, reverse Elliot, "I"-Beam. The wheel ends have been updated with a maintenance free unit type hub bearing.

**Front Axle Specifications:**

Type	Steel Drop Forged Reverse Elliot "I"-Beam.
Rated Capacity	7,275 lbs.
Tread Width	66.1 in.
King Pin Type	Bronze Bushings
Hub Lubrication	Grease
Thrust Bearing	Ball Type (RH)/Roller (LH)

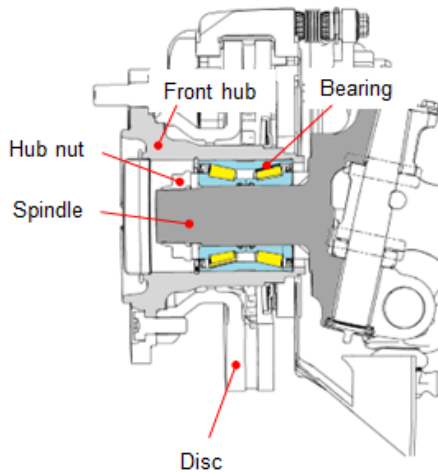

Figure 3: NRR EV Front Axle

**Front Suspension**

The front suspension is tapered leaf springs with stabilizer bar and shock absorbers.

**Front Suspension Specifications:**

Type	Semi Elliptical Springs
Capacity	8,440 lbs.
Effective Length	51.2 in.
Width	2.8 in.
Deflection Rate	1028 lbs./in. (180 N/mm)
No. Leaves	3
Leaf Thickness	3 X 0.71 in.
Stabalizer Bar Diameter	1.65 in.
Stabalizer Bar Thickness	0.16 in.

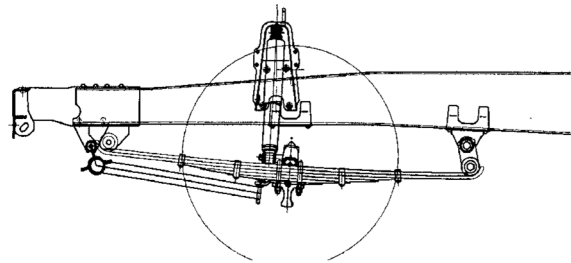

Figure 4: NRR EV Front Suspension

**Steering System**

The NRR EV is equipped with integral power steering with a 18.8-20.9:1 gear ratio and a variable ratio pump. This provides power assist when turning while providing good road feel and feedback driving straight ahead. The system also features a tilt and telescopic steering column that allows adjustment of the steering wheel location for driver comfort and convenience. The steering wheel shape has been updated with a smaller diameter, decreasing from 16.5 in. to 15.5 in. for a more engaging driver experience.



Figure 5: NRR EV Steering Column

**Turning Diameters**

The NRR EV steering also features a 46.5 inside wheel cut angle. This, coupled with the integral power steering, makes the NRR EV an extremely maneuverable truck.

WB	Turning Diameters (design value)	
	B Curb to Curb	C Wall to Wall
109	32.8	38.7
132.5	40.0	44.9
150	45.3	50.2
176	52.5	58.1
200	61.0	67.2
212	66.0	73.0

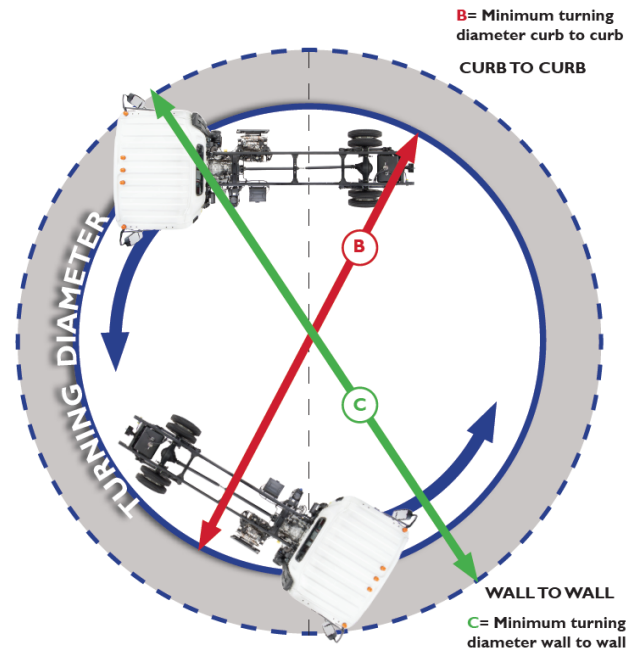

Figure 6: NRR EV Turning Circle Diagram

**Frame**

The frame in the NRR EV is a ladder-type, channel section, straight rail from bumper to end of frame with a rivet-less top flange. Starting with the 25MY, the frame material has been changed to a hot-rolled high tensile strength steel. The new material maintains great formability and weldability, while providing a higher yield strength than the previously used steel. Changes to the frame rail shape include: an increased section height by 14-mm, a thinner 5-mm profile (down from 6-mm), and a new uniform 40-mm (1.575-in.) modular hole pattern to assist with body and equipment mounting. The new front bumper incorporates a crush block where it attaches at the frame ends and features a multi-piece design that allows for individual component replacement if damage occurs.

**Frame Specifications**

	Cab Chassis					
Side Rail Section	9.06 in. X 2.76 in. X 0.20 in.					
Combined Section Modulus	6.65 in <sup>3</sup>					
Yield Strength	54,800 psi					
Rated RBM (per rail)	364,420 lb-in					
WB	109	132.5	150	176	200	212
Number of Crossmembers	5	6	6	6	7	7
Frame Width	33.5 in (850 mm)					

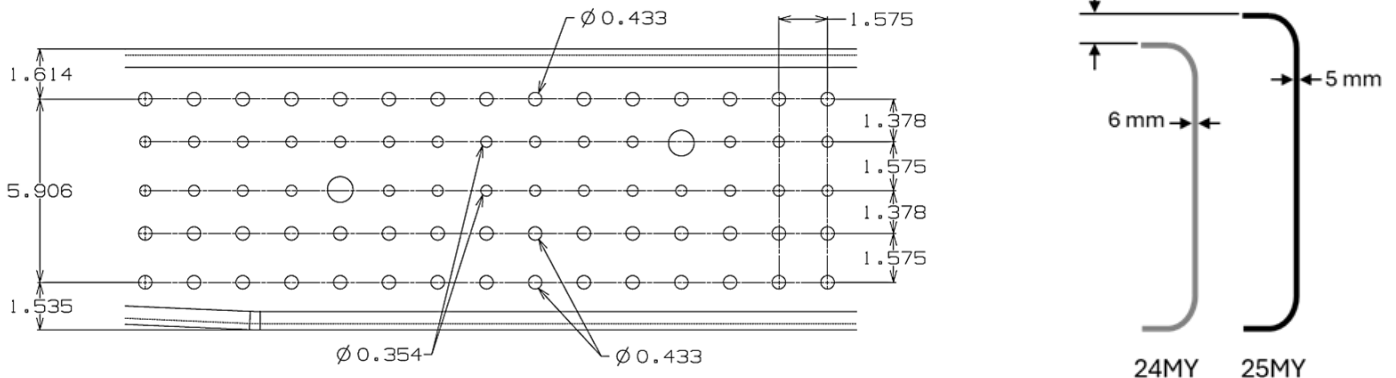

Figure 7: Updated NRR EV Frame

**Rear Axle**

The NRR EV has a full floating rear axle with a banjo type housing and separable carrier. The hub bearings have been updated to a unit type design, providing a maintenance free operation.

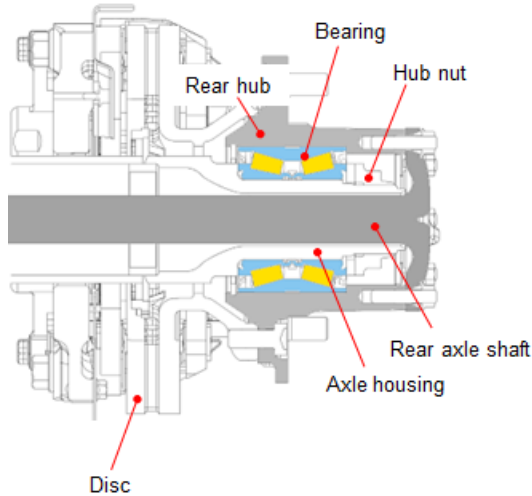

Figure 8: NRR EV Rear Axle

**Rear Axle Specifications**

Model	R066
Type	Full Floating Banjo
Rated Capacity	14,550 lbs.
Tread Width	65.0 in.
Gear Type	Hypoid
Ring Gear Diameter	12.6 in.
Differential Type	4 Pinion Gear
Ratio	5.571
Hub Lubrication	Oil
Oil Type	See Owner's Manual
Oil Capacity	See Owner's Manual

**Rear Suspension**

The rear suspension consists of a multi leaf spring with shock absorbers designed to handle the loads. The long effective spring length design provides excellent ride characteristics.

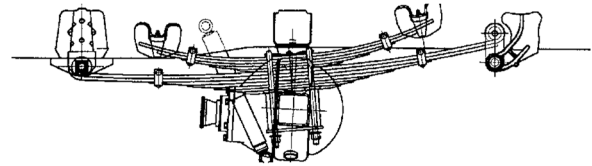

Figure 9: NRR EV Rear Suspension

**Rear Suspension Specifications:**

Type	Multi Leaf Spring
Capacity	14,550 lbs.

**Main Springs**

No. Leaves	5
Effective Length	51.2 in.
Width	2.8 in.
Leaf Thickness	4 X 0.47 in. 1 X 0.43 in.
Deflection Rate	1119 lbs./in. (196N/mm)

**Auxiliary Springs**

No. Leaves	3
Effective Length	33.5 in.
Width	2.8 in.
Leaf Thickness	0.61 in.
Deflection Rate	4,363 lbs./in. (608 N/mm)
Main + Aux. Deflection Rate	5,482 lbs./in. (764 N/mm)

**Tires & Wheels**

**Standard Tire Specifications:**

Manufacturer <sup>[2]</sup>	Dunlop SP688	Bridgestone M895-II
Rev/Mile	643	
Size	225/70R19.5G	
Type	Tubeless Steel Radial Low Rolling Resistance	
Ply Rating	12pr	
Tread	FT/RR All season	
Maximum Load Per Tire <sup>[2]</sup>	at 95 psi.	
Front (lbs)	3,640	
Rear (lbs)	3,415	

**Standard Wheel Specifications:**

Size (in):	19.5 x 6.00 RW
Bolt Holes	6 JIS
Bolt Circle Diameter	8.75 in.
Outside Offset	5.0 in.
No. Piece Rim	1
Rim Type	15° DC
Manufacturer	TOPY
FT/RR Nut Size <sup>[1]</sup>	1.61 in. (41 mm) Bud Hex
Rear Stud Size <sup>[1]</sup>	0.83 in. (21 mm) Square
Nut/Stud Torque Specs.	325 ft.-lb. (440 N-m)

Notes: [1] O.D. wrench size  
[2] Manufacturer selection is not permissible.

**Electrical System**

The electrical system is 12 volt negative ground.

**Batteries**

Low voltage battery, Dual 12-V maintenance free 700 CCA each. A maintenance-free type batteries with threaded posts are wired in parallel. The individual battery has a 160 minute reserve capacity rating. The battery box has a lockable battery hold down to prevent theft.

**Electrical System Features:**

- Flush surface LED headlamps with integral parking, turn signal, cornering lamp, and daytime running lights.
- Combined rear lamps: Turn Signal, Stop, and Backup
- LED Identification, clearance lamp, license plate lamp
- Back up alarm and body mounting circuits electrical connectors
- Trailer lighting and trailer brake controller wiring connectors
- Auxiliary power connector behind dash

The 2025MY NRR EV chassis introduces a number of new electrical control components to expand the vehicles current and future functionality. These changes include a new Central ECU, Central Gateway Control Unit, Input/Output Control Unit, Body Control Module, and FMS CAN Interface Control Unit.

**Central ECU**

The new central ECU has been adopted to accommodate the increasingly sophisticated control units and sensors associated with advanced safety devices. This module manages ADAS-related controls and exhaust brake operations including full-range adaptive cruise control, inter-vehicular distance warning, and preceding vehicle departure notification functions. The central ECU will send the exhaust brake operation request signal to the ECM when requested by the driver and the proper conditions are met.

**Central Gateway Control Unit**

This module serves as the main hub for all 7-CAN communication circuits within the vehicle. Scan tool communication with any of the on board ECU's must first pass through the central gateway control unit.

**Input/Output Control Unit**

The I/O Control Unit is responsible for a wide variety of vehicle systems, and consolidates information from various vehicle controllers collected over the CAN communication circuit. This module features an integrated G-Sensor to capture changes in vehicle posture and the current road gradient to aid with electric parking brake control. The I/O Control Unit also receives information from various switches and sensors within the chassis and converts those signals into CAN communications (for example: parking brake switch, ignition switch, ADAS driver controls, front and rear brake pressures, and the automatic headlight illuminance sensor).

**Body Control Module**

The body control module (BCM) manages an array of functions that are controlled by switches and sensors within the cab - including automatic headlights, power door locks, windshield wipers, flashers, stoplights, interior lights, and taillights.

**FMS CAN Interface Control Unit**

With the 25MY NRR EV, a CAN interface signal converter module is standard on the chassis and is designed to transfer information between the vehicle and an upfitter installed external CAN device. Standard output data includes engine speed, vehicle speed, vehicle mileage, and VIN among others.

**Interior Trim Features**

For the 2025MY, Isuzu introduced an all new cab interior with features that increase comfort, reduce driver fatigue, and enhance safety. Drivers will find the cab has a spacious environment with ample shoulder and head room. The standard high back driver's and passenger seats have been made slightly taller (added 40 mm) to improve comfort for larger drivers. The center passenger seat has a tray mounted on the back side to provide a convenient work area for the driver inside the cab out of the elements. The driver's seat has also been upgraded with a new folding arm rest and a new slide adjustment that can move further and lock into more intervals along the range. The slide adjustment lever has been improved into a bar design that spans the entire width of the seat for easier handling.

Additional storage for maps and other papers is provided in easy to reach door pockets, the passenger seat back, as well as several built-in storage areas in the dash. The overhead storage shelf has been expanded with a new center section and a rear organizer tray is standard equipment on all N-Series chassis. A LED interior dome light is installed for a brighter cab in night time operations.

To further enhance safety, the NRR EV offers a wide range of standard and optional safety features. SRS frontal airbags have been introduced for the driver and outboard passenger seats as a standard feature on every 2025MY NRR EV truck. Airbags provide supplemental protection and are designed to work in combination with seatbelts. The passenger airbag on-off switch is located on the passenger side of the instrument panel and is visible only when the passenger front door is open.

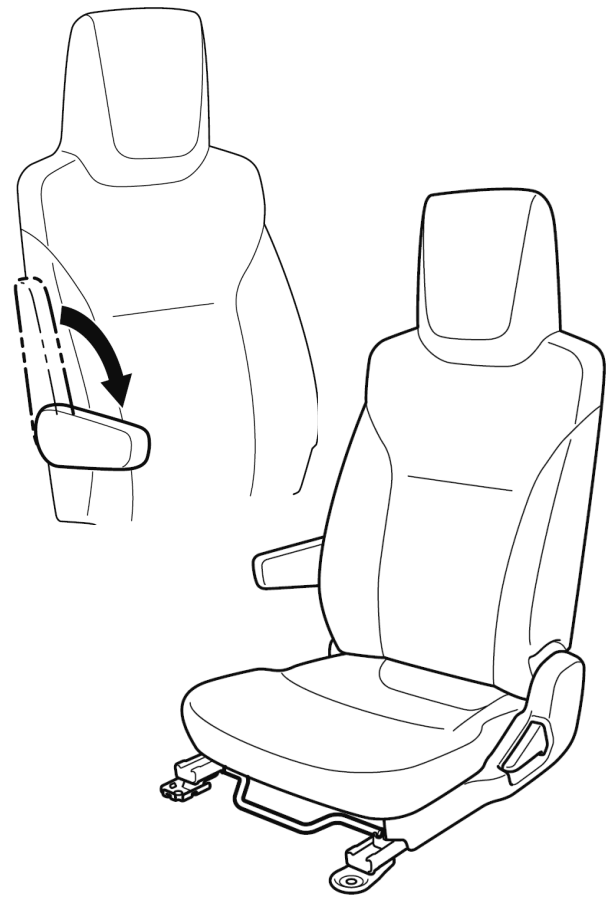

Figure 11: Driver's Arm Rest and Seat Adjustment Lever

No.	Equipment
1	Sun visor
2	Remote control mirror switch (optional)
3	Overhead tray
4	Dome light
5	Seat belt
6	Coat hook

No.	Equipment
7	Seat
8	Parking brake lever (standard)
	Electric parking brake switch (optional)
9	Selector lever
10	Fully adjustable steering

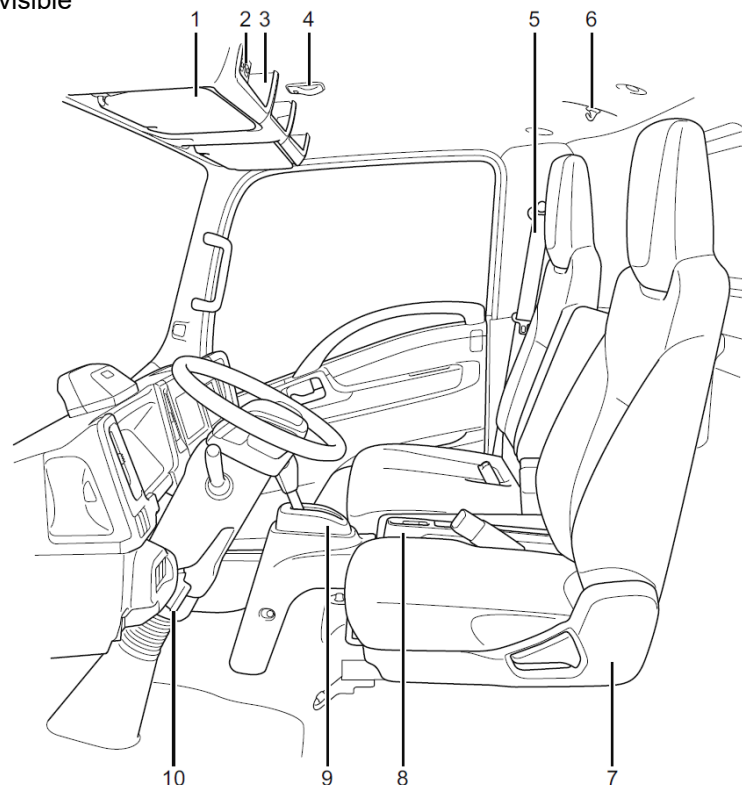
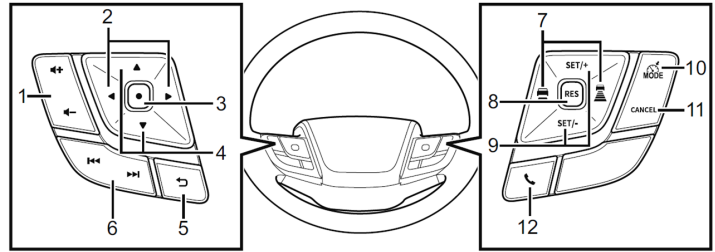

Figure 12: Updated Interior

Steering wheel construction has been significantly updated for the 2025MY NRR EV. The center of the wheel now features an integrated SRS frontal airbag and an array of switches for controlling the radio, phone calls, ADAS, and MID functions. To improve the driving experience, the overall size has been decreased from 16-in. to 15-in. and updated materials wrap the wheel.



No.	Equipment	Page	No.	Equipment	Page
1	Volume adjust button	6-22	8	Resume switch	
2	Right/left switch	6-47	9	Set switch	4-94
3	Enter switch	3-29	10	Mode switch	5-2*
4	Up/down switch		11	Cancel switch	
5	Return switch		12	Off hook/on hook button	6-47
6	Tune/track button	6-22			
7	Following distance setting switch (optional)	5-14			

\*: Model with Advanced Driver Assistance System only

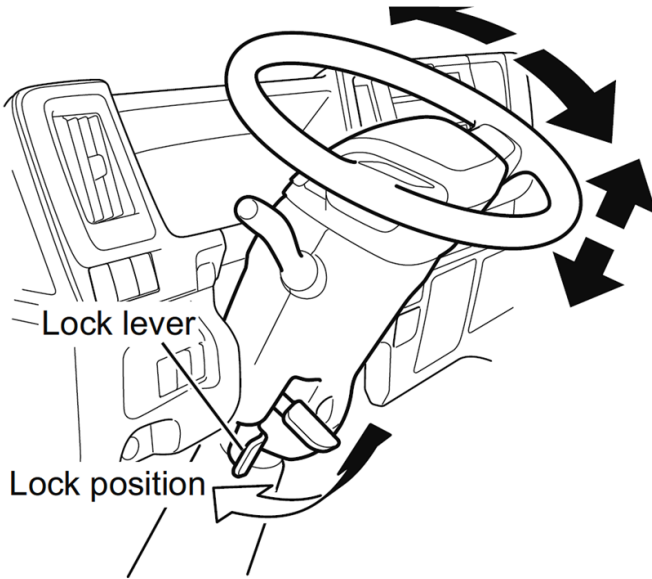

Figure 13: NRR EV Steering Column

NRR EV chassis equipped with the factory standard ADAS package will instead feature an electronic parking brake that is controlled by a switch as shown in Figure 15. This location provides an unobstructed floor for increased driver comfort. The rubber floor cover is durable and easy to maintain. A heavy-duty floor mat is standard. The automotive style instrument panel has a low-profile design for improved downward visibility. The cab is fully trimmed to provide a quieter environment. Cup holders are mounted between the seats within convenient reach of the driver and will handle large convenience store cups. A slide out, dash mounted cup holder accommodates smaller sized cups.

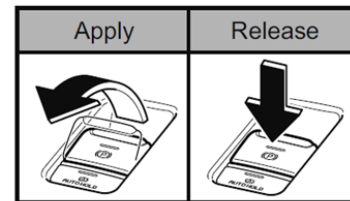
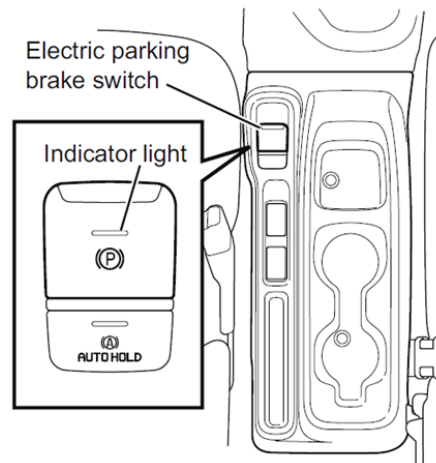

Figure 15: NRR EV Electric Parking Brake

**Instrumentation**

The instrument cluster of the 2025MY N-Series cab has been fully redesigned with new 7-in color Multi-Information Display (MID) in addition to the speedometer, tachometer, fuel gauges, and temperature gauges. Combined with the redesigned steering wheel, instrument visibility is greatly enhanced.

Frequently used switches are styled for easy operation, and illuminated for operation at night. ISO symbols are used on the switches and instrument panel for standard recognition of control components. The combination switches are designed to fit naturally in the hand. Their function is clearly marked on the lever for easy recognition. Intermittent wiper operation intervals have been improved for a greater range of speed options. A headlight washer function has also been added to these controls for a quick and easy way of clearing the LED headlights of ice or road spray. The headlights control switch now features an AUTO function that employs a new ambient light sensor mounted ahead of the driver, just behind the windshield. This system will automatically turn on the headlights when driving in low light conditions. Cornering lights are standard to improve nighttime visibility when the turn signals are operated and headlights are on.

Standard cruise control is equipped on every N-Series vehicle with new controls positioned on the steering wheel for easy access. An AM/FM Radio with aux input, USB port, and Bluetooth is standard equipment. The dash also has a "5 DIN" opening suitable for other electronic equipment. The NRR EV will come standard with Automatic air conditioning. When the AUTO switch is pressed, the air conditioning system will operate automatically. The outlets and fan speed will adjust by themselves to reach the set desired temperature.

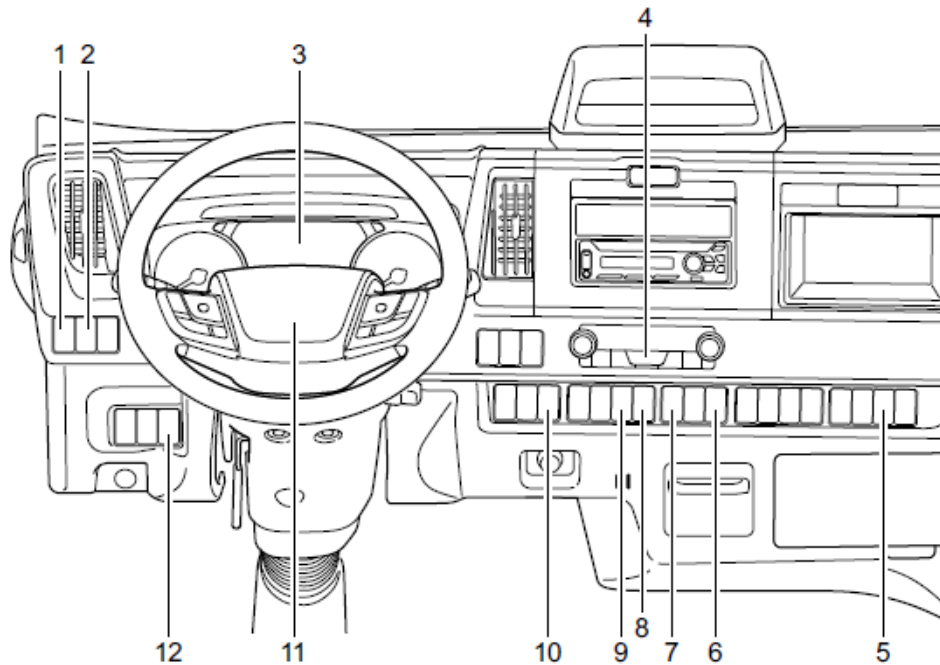

**Dash Panel Switches and Controls**

No.	Description	No.	Description
1	Front fog light switch (optional)	8	LDWS switch
2	Rear body interior light switch	9	ESC OFF switch
3	Instruments, warning lights and indicator lights	10	Outside rearview mirror heater switch (optional)
4	Hazard warning flasher switch	11	Horn Button
5	USB power outlet	12	Driver's SRS Frontal Airbag
6	Seat heater switch		Instrumental panel light level control
7	E-HEAT switch		

Figure 16: NRR EV Dash Panel

Warning and Indicator Lights

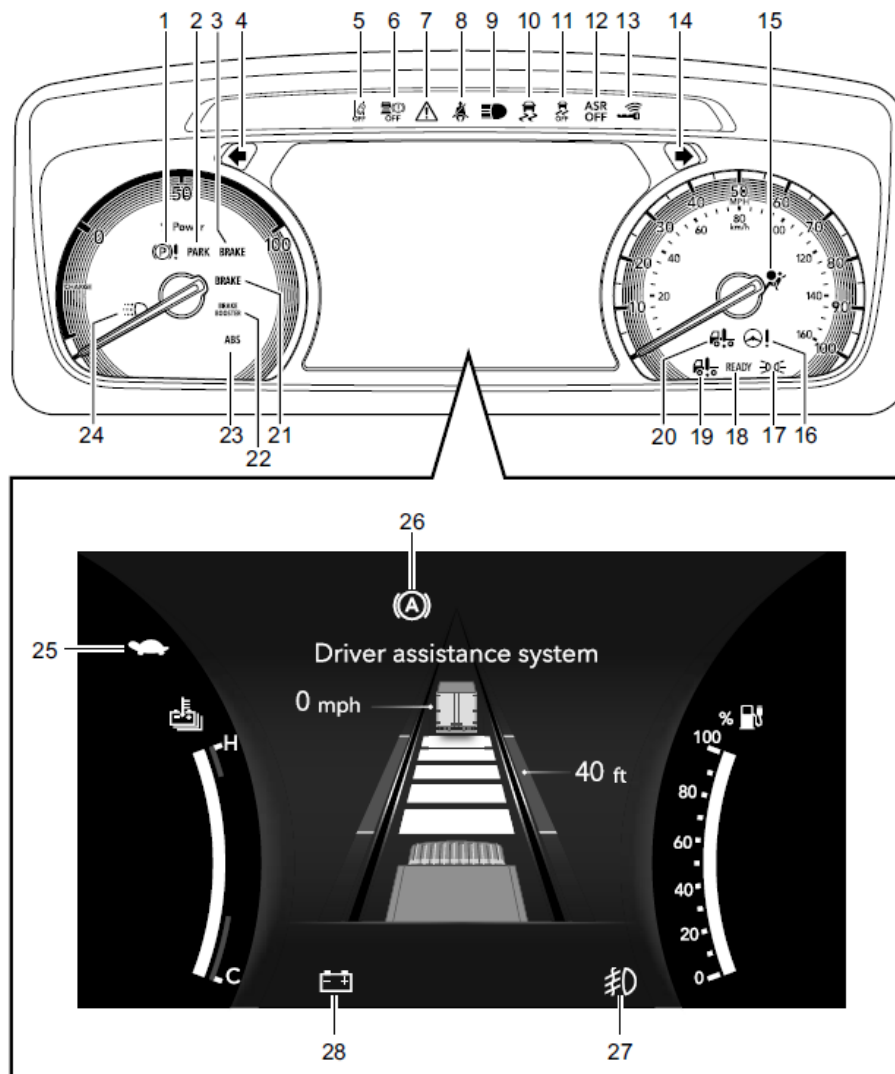

No.	Description	No.	Description
1	Electric parking brake warning light	18	READY indicator light
2	Parking brake warning light	19	EV system malfunction warning light
3	Brake system warning light	20	EV system serious malfunction warning light
4	Turn signal and hazard warning flasher indicator light - Left	21	Brake system warning light
5	LDWS OFF indicator light	22	Brake low vacuum warning light
6	AEBS OFF indicator light	23	ABS warning light
7	Master warning light	24	Daytime running lights (DRL) indicator light
8	Seat belt warning light	25	Reduced power warning light
9	Headlights high beam indicator light	26	Auto Brake Hold indicator light
10	ESC warning light	26	Auto Brake Hold warning light
11	ESC OFF indicator light	27	Fog lights indicator light (optional)
12	ASR OFF indicator light	28	12-volt auxiliary battery discharge warning light
13	Keyless entry and start system warning light		
14	Turn signal and hazard warning flasher indicator light - Right		
15	SRS Frontal airbag warning light		
16	Steering system warning light		
17	Lights on indicator light		

Figure 17: Warning and Indicator Lights

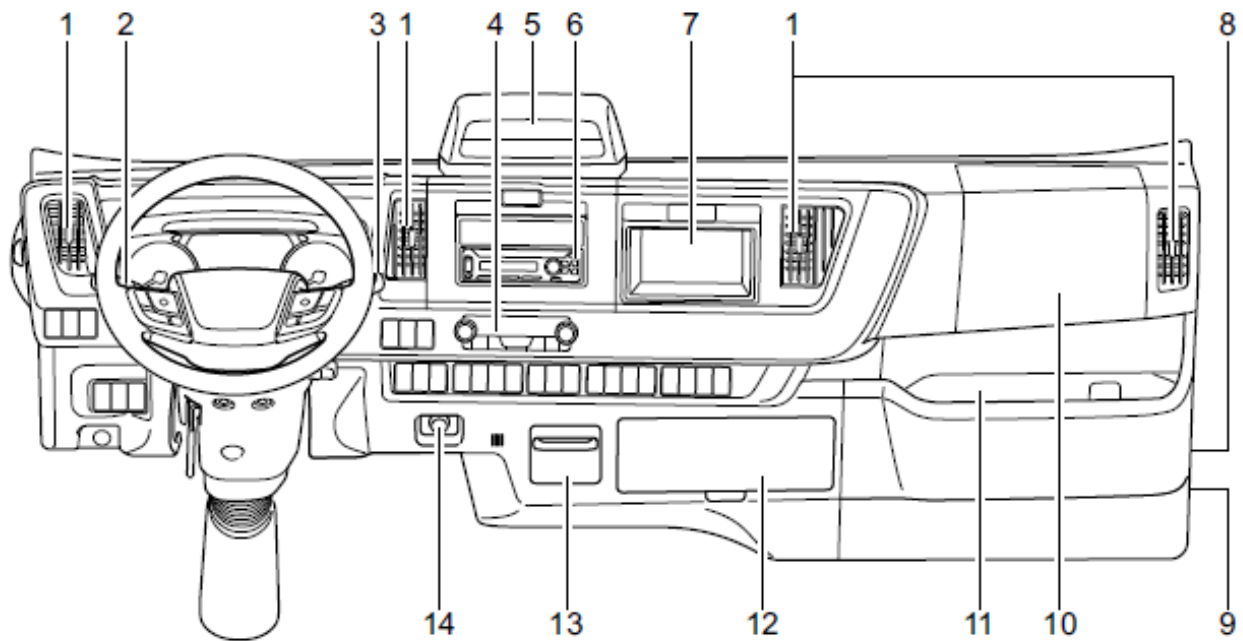

No.	Description
1	Air flow direction control lever
2	Combination light control switch & turn signal switch
3	Regenerative braking switch & Windshield wiper and windshield washer switches
4	Automatic air conditioner
5	Small article storage pocket in camera cover
6	Radio with USB/Bluetooth®
7	Small article storage pocket
8	Windshield washer fluid tank
9	Passenger Airbag on-off switch
10	Outboard Passenger SRS Frontal Airbag
11	Passenger side cup holder and storage pocket
12	Relay box
13	Cup holder
14	Accessory power outlet

Figure 18: NRR EV Instrument Panel

---

# DATA BOOK REVISION

---

**Date:**

**Subject:**

---