

R3E®

0
1
2
3



P7-C CLASS 4
ELECTRIC CHASSIS CAB



YOU WANT AN EV THAT'S VERSATILE, FLEXIBLE, MODULAR AND CAN HANDLE THE DEMANDS OF CITY DRIVING.

CONSIDER IT DONE.

Introducing the P7-C class 4 chassis cab Powered By REE.®

It's electric, but it's not like anything you've seen before. The P7-C was made to improve operational efficiencies. Agile maneuvering, zero emissions, a low step-in height and excellent visibility all add up to a safe and efficient working environment. You don't need to settle for legacy technology when transitioning your fleet to electric. You can make the most out of your investment now.

The P7-C is designed around four ingenious REEcorner® modules.

REEcorner swaps in less than 1 hour. Each are individually controlled, with the REEcenter coordinating all four corner's x-by-wire technology. Traditional mechanical components have been eliminated between the wheels to create a fully modular design that's nothing short of revolutionary.



39 ft. Turning Circle¹

Navigate tight urban spaces with All Wheel Steer (AWS) for greater maneuverability.



X-by-Wire Control

Each corner is independent with redundancies for enhanced fail-operational design.



24 in. Platform Height

Low step-in height saves time while reducing driver fatigue and injury risk.





Aerodynamic Design

Flat and low underbody reduces drag and energy consumption while maximizing range.



Clear Sight Lines

Large windshield and side glass reduces blind spots and offer optimum visibility for busy urban environments.



Low TCO

Designed for reduced downtime, quick servicing and long spans to pay off in the near- and long-term.

(1) All illustrations, equipment, and technical data in this brochure are based on the latest information available at the time of publication. REE Automotive Ltd. ("REE") reserves the right to make changes at any time, without notice, in prices, colors, materials, equipment, specifications and models and to discontinue models or equipment. REE vehicles are assembled from component parts manufactured by REE, its affiliated companies and by independent suppliers who manufacture such components to REE's exacting standards for quality, performance and safety. Some vehicles are shown with optional equipment. REE urges drivers and operators to follow traffic rules, which are meant to keep them safe on roads. Safety or driver assistance features are no substitute for the driver's or operator's responsibility to operate the vehicle in a safe manner. Pre-production P7-C Images. Production model may vary.



TECHNOLOGY THAT TARGETS A LOW TOTAL COST OF OWNERSHIP.

REECORNER[®]
CHANGES IN
UNDER 1 HOUR

**SMART
PREVENTATIVE
MAINTENANCE**

**ALL WHEEL DRIVE
REGENERATIVE
BRAKING FROM
ALL 4 CORNERS**

**ALL WHEEL
STEER &
INDEPENDENT
SUSPENSION**

**LARGE HEATED
WINDSHIELD
PROVIDES HIGH
VISIBILITY FOR
URBAN AREAS**

1) REEcorner™ replacement timing based on authorized dealer partners. Timing can depend on availability of parts and other service orders at the dealer. Pre-production P7-C images. Production model may vary.



+

**OPERATING COST
SAVINGS: REDUCED
MAINTENANCE AND
INCREASED RESIDUALS**

REECORNER® MODULE

Steering, braking, suspension, powertrain and control—the critical components in any vehicle—have been integrated into a single compact by-wire controlled module and strategically located between the chassis and the wheel. A central ECU keeps all four corners working together in harmony.



REE PLATFORM

The REE platform is fully flat end-to-end, thanks to REE's proprietary x-by-wire technology providing full steer-by-wire, brake-by-wire, and drive-by-wire independent wheel control. This enables a fully flat chassis, low step-in height, and improved vehicle maneuverability.



HIGH-ENERGY BATTERY

Large capacity, high energy Lithium-ion battery with the flexibility of up to 14.7 kW AC and 100 kW DC charging.



EXPANSIVE CABIN SPACE

High cab roof and low floor platform allow drivers to stand and move about cab with ease

LARGE HMI SCREEN

Central HMI screen to reduce driver distraction

VISIBILITY

Ample window space for excellent visibility in tight urban environments and pedestrian heavy areas

HARD-WEARING MATERIALS

Help ensure vehicle can be easily maintained



AS COMFORTABLE AS IT IS CONFIGURABLE.

STANDARD FEATURES: EXTERIOR

- LED Headlamps
- Charge Port Lighting
- Replaceable Side and Front Panels
- Keyless Entry
- Manual Exterior Mirrors
- Heated Windshield
- Dual Speed Wipers
- Tire Pressure Monitoring

INTERIOR

- 8" Instrument Cluster
- 12.3" Center Infotainment Screen w/ Bluetooth Connectivity
- 4 Speaker System
- Push Button Gear Selector



- Electronic Parking Brake + Auto Park
- Hazard Switch
- Turn + Exterior Light Control Stalk
- Heated Steering Wheel with Multi-function Controls
- Single Zone Temperature Control with Combination Carbon Air Filter and Front Windshield Defrost
- Manual Tilt Steering Column
- Acoustic Vehicle Alert System (AVAS)
- Seat Belt Warning
- Solid Bulkhead (optional Cut-away or Walk-through)
- Driver and Passenger Captain's Chairs (optional 3 passenger seating)
- Wheel Arch Consoles with 2 x USB A + 2 x USB C Ports, Storage and Cupholders



SPECIFICATIONS¹

HIGHLIGHTS

GVWR	16,000 lbs
Weight Class	Class 4
Payload	6,000 lbs
Peak Power	536 hp
Range³	150 mi
X-by-Wire: All Wheel Drive, All Wheel Steer, All Wheel Brake	

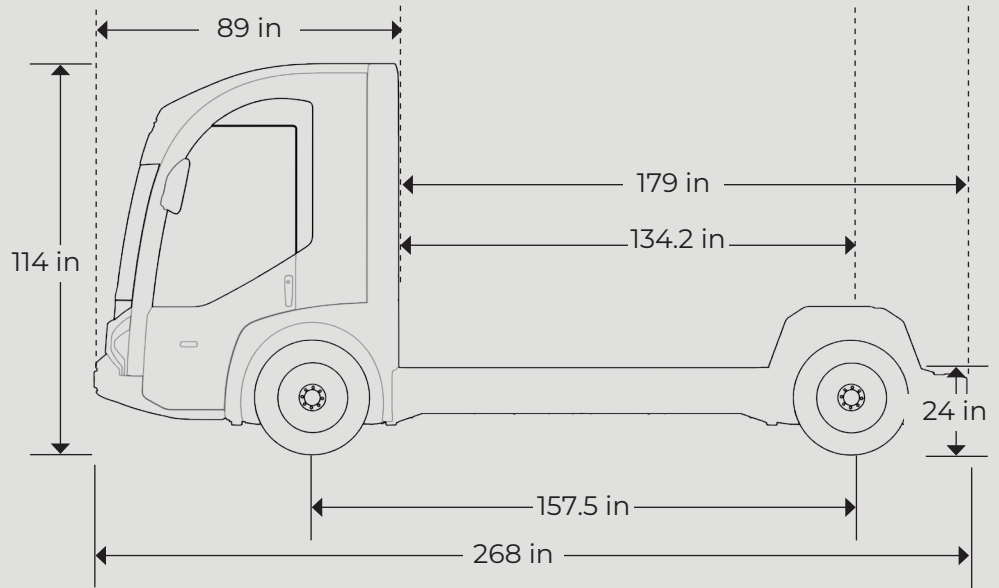

CHASSIS CAB DIMENSIONS

Height (cab)	114 in.
Wheelbase	157.5 in.
Length (including bumper)	268 in.
Width (wheel nut to wheel nut)	97.5 in.
Width Between Wheel Arch	50 in.
Cab Length	89 in.
Cab to End Frame	179 in.
Cab to Axle	134.2 in.
Cab Floor Height	24 in.
Ground Clearance	10.5 in.
Front Overhang	66 in.
Rear Overhang	44 in.
Front Track	81.5 in.
Rear Track	81.5 in.
Approach Angle @ GVW	13°
Departure Angle @ GVW	21°
Breakover Angle @ GVW	12°

BRAKING & TRACTION

Peak Torque	8,628 ft-lb
Peak Power	536 hp
Max Speed	75 mph
Drive	AWD
Braking System	Electro-hydraulic four corner by-wire

WEIGHTS

Weight Class	Class 4
Gross Vehicle Weight	16,000 lbs
Max GAWR	8,980 lbs
Payload ²	6,000 lbs

STEERING

Steering	4 x independent steer-by-wire
Min Turn Diameter	39 ft.
Sensors	Motor encoder, temperature, pinion angle, hall sensors

TIRES & WHEELS

Tire	245/70 R19.5
Wheel	19.5 in.

SUSPENSION

Type	Independent Wishbone Twin coil over dampers
Suspension Travel	Jounce: 2.75 in. Rebound: -5.12 in.
Sensors	Wheel speed, ride height, TPMS
Static Camber Value	0.0 +/- 1.0°
Static Castor Value	0.0 +/- 1.0°

BATTERY SYSTEM

HV Battery Voltage (nominal)	400 V
Range ³	150 miles
HV Battery Charging (CCS1 Plug)	Up to 14.7 kW AC Up to 100 kW DC
Lifetime	>5000 charges

(1) Vehicle specifications are subject to change without notice. All data is approximate. (2) Payload target based on preproduction model. Production model may vary and are subject to manufacturing tolerances. (3) REE estimate based on a full charge and subject to change prior to production. REE estimated range based on analytical simulations using typical urban drive cycle. Actual range may vary based on several factors, including temperature, terrain, battery age, loading, and usage and maintenance. (4) 48 V for steering and brakes. 12 V available in cab for accessories. Actual features and specifications of the vehicle may vary from the visuals shown herein. REE reserves the right to alter, add or remove any feature and/or specification without prior notice. Technology and branding in this brochure have intellectual property rights owned by REE Automotive, including patents, trademarks, trade secrets, and copyrights.

REE



**BOOK
A DEMO**



**BECOME
A DEALER**



www.ree.auto