

**ALL-NEW.
ALL-ELECTRIC.**

2025 BOLLINGER B4

BOLLINGER MOTORS

> **ELECTRIC HEART. DETROIT SOUL.**

The all-new, all-electric Bollinger B4 is available and ready to electrify your commercial truck fleet. Our class 4 commercial truck is built from the ground up in the heart of the automotive industry, offering unrivaled performance, protection and versatility, and has achieved NHTSA, EPA and CARB certification.

> **THE BOLLINGER B4 CHASSIS - RELIABLE PROTECTION & DURABLE PERFORMANCE.**

The Bollinger difference can be found in our proprietary, purpose-built commercial EV chassis. With a width of 40" compared to the traditional 34", the B4's frame provides the ideal space for securely housing and protecting the dual Our Next Energy (ONE) Aries LFP batteries and all other components between the rails.

The placement of the batteries and components within the frame ensures weight is centered and low, resulting in improved driving dynamics. The Quad-Bend tapered frame enhances maneuverability, allowing a 40" frame to turn like a 34" frame, creating a tight 46' turning circle.

Flat frame rails streamline upfits with minimal customization required, meaning your truck could be on the road fast. Any upfit. No problem.

When maintenance or repairs are needed, all components, including batteries, are easily accessible from below the frame, creating less downtime in the shop for your trucks.

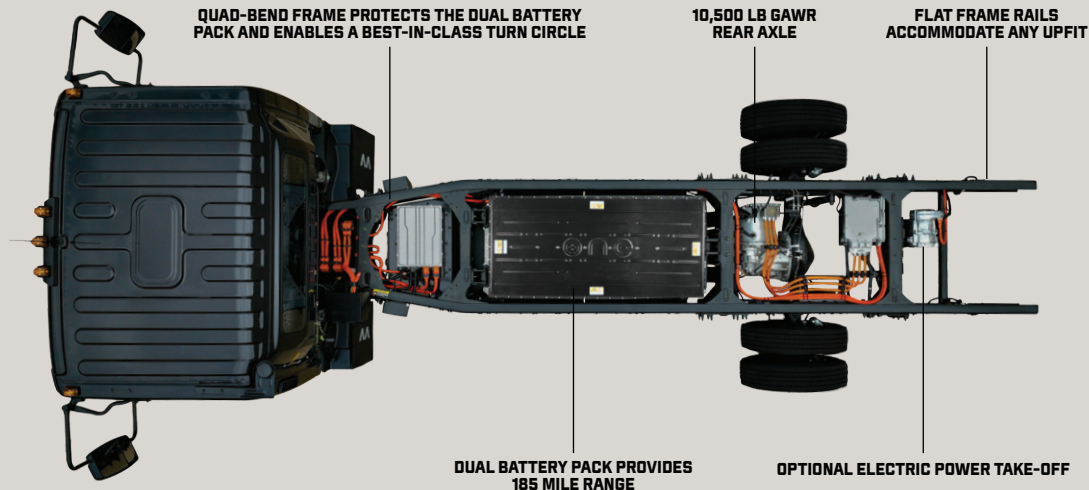

> **BOLLINGER B4: GREAT TRUCK. GREAT VALUE.**

We're confident the 2025 Bollinger B4 is the right truck for your fleet, but if you need a little more convincing, our truck qualifies for an IRS tax credit of up to \$40,000. Plus, there are other state and local incentives available that could help eligible businesses realize even greater savings, like California's HVIP which could save you up to \$60,000, or New York's NYTVIP incentive which could save you up to \$100,000. Talk with your Bollinger Motors representative or authorized Dealer for more information.



BOLLINGER MOTORS

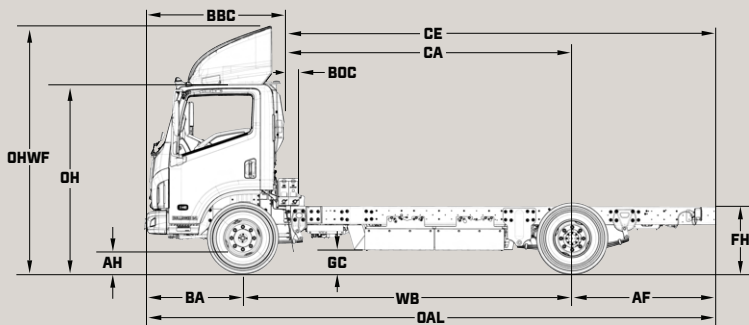
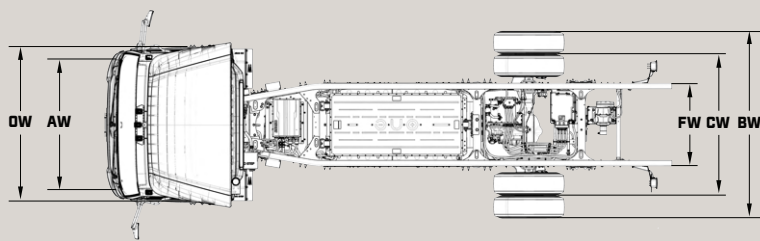

DIMENSIONS

WIDTH (OW)	75.3"
LENGTH (OAL)	273.5"
HEIGHT (OH)	92.7"
HEIGHT WITH FAIRING (OHWF)	118"
WHEELBASE (WB)	158"
FRONT TRACK (AW)	62.5"
REAR TRACK (BW)	88.4"
RAIL HEIGHT (FH)	32"
CAB-TO-AXLE LENGTH (CA)	138"
FRONT OVERHANG (BA)	46.3"
REAR OVERHANG (AF)	69"
APPROACH ANGLE	19°
BREAKOVER ANGLE	14°
DEPARTURE ANGLE	18°
GROUND CLEARANCE(GC)	9"

B4 SPECIFICATIONS

VEHICLE CLASS	4
GVWR	15,500 LBS
REAR AXLE DUAL RWD	10,500 LBS
SOLID FRONT AXLE	6,500 LBS
PAYLOAD	7,325 LBS
TURN CIRCLE	46'
CAB TO BOX	8"
FRAME WIDTH	40"
BODY LENGTH	16'-18'
TIRE SIZE	225/70R-19.5G
HORSEPOWER	323HP, 241 KW PEAK
TORQUE	675 FT LBS, 915 NM
RANGE	185 MILES
RATED POWER	235 KW MAXIMUM
BATTERY CAPACITY	158 KWH
AC LVL 2 CHARGE TIME 0-100%	9 HRS @ 19.2 KW
DC FAST CHARGE TIME 0-100%	2 HRS @ 110 KW

B4 OPTIONS & ACCESSORIES

MOBILEYE ADVANCED DRIVER ASSISTANCE SYSTEM:

- Forward collision warning
- Pedestrian & cyclist collision warning
- Lane departure warning
- Headway monitoring & warning
- Speed limit indicator

96" MIRROR BRACKET

CAB FAIRING

TAIL LIGHT KIT

WHEEL COLORS:

- White
- Black
- Grey

CAB COLORS

White (standard)

*Custom colors require paint codes, additional lead times, and minimum quantities

ELECTRIC POWER TAKEOFF (EPTO) UNIT

Available January 2025

WARRANTY COVERAGE

BUMPER TO BUMPER: 3 years/36,000 miles

Provides warranty coverage against defects in material and workmanship.

*Adjustments and expendables such as bulbs and fuses are covered for 12 months/unlimited.

POWERTRAIN / PROPULSION: 5 years/50,000 miles

Provides warranty coverage against defects in material and workmanship.

AIR CONDITIONING: 5 years/ 50,000 miles

Provides warranty coverage against defects in material and workmanship.

HIGH VOLTAGE BATTERY: 8 years/100,000 miles

Provides warranty coverage against defects in material and workmanship.

FRAME RAILS & CROSS MEMBER: 5 years/unlimited

Provides warranty coverage against structural cracks in the frame caused by defects in material and workmanship.

CORROSION (perforation only): 5 years/unlimited

Provides warranty coverage against corrosion perforation of the cab structure.

TIRES: 4 years/unlimited

Goodyear Unisteel Limited Warranty.

*Refer to the Goodyear tire warranty located in the owners/operator's information.

For more information visit: BOLLINGERMOTORS.COM