



EV STAR

CARGO PLUS



Transportation **EV**olved

All-Electric  Purpose-Built  Zero-Emission

CHARGING



Dual (AC/DC)
Level-2, J1772, up to 19.2 kW AC, ~8 hrs
DCFC, CCS-1, 60 kW, ~2 hrs
Wireless DC (option), 60 kW, ~2 hrs



RANGE

Up to 150 miles



BATTERY

118 kWh



PAYLOAD CAPACITY

Up to 5,000 lbs



GreenPower
MOTOR COMPANY

USA 833-274-5144
Canada 604-563-4144
GreenPowerMotor.com
Sales@GreenPowerMotor.com

EV STAR CARGO PLUS TECHNICAL DATA

CLASSIFICATION

Class 4

GVWR

14,330 lbs.

PAYLOAD CAPACITY *

Up to 5,000 lbs.

LENGTH ④

25 ft.

WIDTH ③

96 in.

EXTERIOR HEIGHT ②

121 in.

WHEELBASE ①

170 in.

AXLE WEIGHT RATING

4,409 lbs. (front), 9,920 lbs. (rear)

APPROACH

14.7 degrees

LIFT GATE *

Hydraulic lift

LIFT GATE LOAD CAPACITY *

1,600 lbs., 45 in. deep x 84 in. wide

BOX BODY OEM

Lion Truck Body, aluminum high cube

MAX SEATING CAPACITY

2 cabin seats

TIRES

215 / 75R / 17.5 (qty. 6)

HVAC

Electrical

ECU COMMUNICATION

CAN BUS, J1939

FRAME / BODY / ROOF

Steel / Aluminum

BATTERY CHEMISTRY

LiFePo4

BATTERY VOLTAGE

576 V

BATTERY CAPACITY

118 kWh

RANGE *

Up to 150 miles

FUEL ECONOMY *

48 mpge, 0.77 kWh/mi, 1.3 mi/kWh

TOP SPEED

68 mph

MOTOR

Dana tm4

MOTOR POWER

150 kW max

TRANSMISSION

Direct drive, no transmission

CHARGING

Dual (AC/DC)

Level-2, J1772, up to 19.2 kW AC, ~8 hrs

DCFC, CCS-1, 60 kW, ~2 hrs

Wireless DC (option), 60 kW, ~2 hrs



EV Star Cargo Plus has 836 cubic feet of cargo capacity.

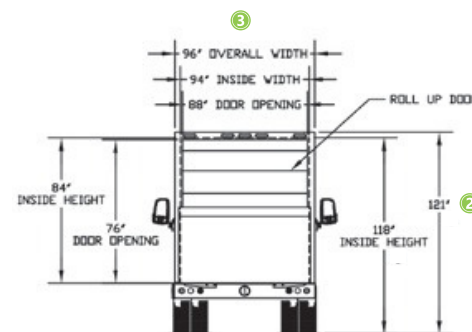
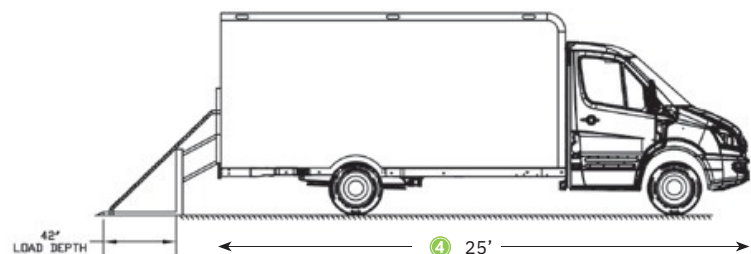
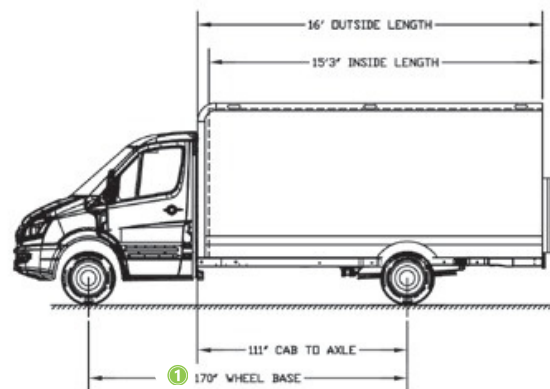

The box dimensions and configurations on this page represent a standard dry freight box. The liftgate as pictured is an option and not part of the standard configuration. A wide range of other dimensions and configurations exist, or you can design your own to meet specific application needs.

*Specifications can vary by region, application and availability.

Disclosure: No representation or warranty is expressly or impliedly given as to its accuracy, completeness or correctness.

The all-electric, purpose-built EV Star Cargo Plus has established the new standard of performance, safety and sustainability for the cargo and delivery market.

What Sets the EV Star Cargo Plus Apart

All-Electric EV Star Cargo Plus

- ☞ Purpose-built on the EV Star Cab & Chassis platform to be an electric vehicle.
- ☞ Optimal battery placement provides for a lower center of gravity resulting in maximum cargo capacity.
- ☞ Improved payload to range ratio.
- ☞ Single manufacturing entity for ease of warranty claims, service and overall customer experience.

Other Electric Cargo Vans

Conversion vehicles not designed as electric vehicles from ground up.

Higher center of gravity means less cargo volume.

Multiple batteries pit range against payload.

Multiple manufactures for different vehicle parts.



EV Star Cargo Plus Refrigerated Truck:

- ☞ Higher payload due to eTRU being powered by the high-voltage battery.
- ☞ Design is 10% lighter than any comparable low-voltage unit currently sold in the US.
- ☞ Design is 20% more efficient than any comparable low-voltage unit currently sold in the US.
- ☞ Multiple insulation options available.

The EV Star Cargo Plus can be upgraded to a Refrigerated Truck with full interior insulation.

GreenPower EV Star Cargo Plus Warranty

GREENPOWER MOTOR COMPANY WARRANTS EACH ALL-ELECTRIC, PURPOSE-BUILT EV STAR CARGO PLUS TO BE FREE FROM DEFECTS IN MATERIAL AND WORKMANSHIP UNDER NORMAL USE AND SERVICE WITHIN THE LIMITS IDENTIFIED BELOW:**

- ☞ Structure and body integrity against corrosion — five years.
- ☞ Chassis structure — three years/250,000 miles.
- ☞ Body and window frames against leakage — two years.
- ☞ Drivetrain — three years/150,000 miles.
- ☞ High-voltage battery system — five years/100,000 miles.
- ☞ Basic body structure — three years.
- ☞ HVAC system — one year.
- ☞ Exterior paint — one year.
- ☞ Complete vehicle — one year.
- ☞ Lion Truck Body warranty — three years.**

*Warranty can vary by region, application and availability.

** Lion Truck Body warranty is covered only when the product is installed by Lion Truck Body & authorized Lion Truck Body distributors, properly maintained and used for its design and purpose. Warranty is non-transferrable to a new owner.

EV STAR

CAB & CHASSIS



The all-electric GreenPower Motor Company proprietary EV Star Cab & Chassis was designed to take on any mid and last-mile delivery while maintaining the benefits of being a zero-emissions vehicle. It is purpose-built to be an electric vehicle and is designed to accommodate a multitude of upfits or bodies for different use cases. With a carrying capacity of 7,000 pounds and a range of up to 150 miles, the GreenPower EV Star Cab & Chassis is the perfect vehicle for any fleet. Its clean sheet design approach facilitates optimal battery pack placement and weight distribution, allowing the vehicle to accommodate a larger energy supply, deliver a longer range and set the new standard for zero-emission goods and people transportation.

- Proven reliability and efficiency in a wide variety of operational settings with more than 500 deliveries in North America.
- The EV Star Cab & Chassis is the foundation for the EV Star Passenger Van, a vehicle that passed the FTA Altoona Bus Testing program with one of the highest scores ever recorded, an achievement that shows the safety, strength and durability of the underlying chassis and running gear.
- Dual port charging as a standard feature. Wireless charging available as an option.
- Optimal battery placement to maximize payload and provide for a low center of gravity.

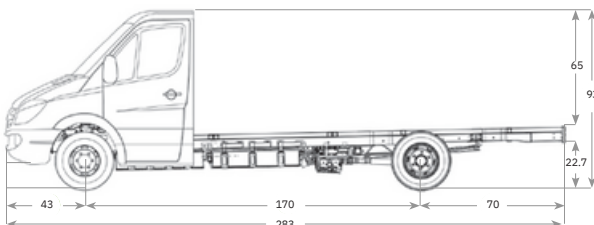

CHARGING
 Dual (AC/DC)
 Level-2, J1772, up to 19.2 kW AC, ~8 hrs
 DCFC, CCS-1, 60 kW, ~2 hrs
 Wireless DC (option), 60 kW, ~2 hrs

RANGE
 Up to 150 miles

BATTERY
 118 kWh

CARRYING CAPACITY
 7,000 lbs

4/24 REVISION



USA 833-274-5144
 Canada 604-563-4144
 GreenPowerMotor.com
 Sales@GreenPowerMotor.com

Transportation EVolved
 All-Electric Purpose-Built Zero-Emission